

B

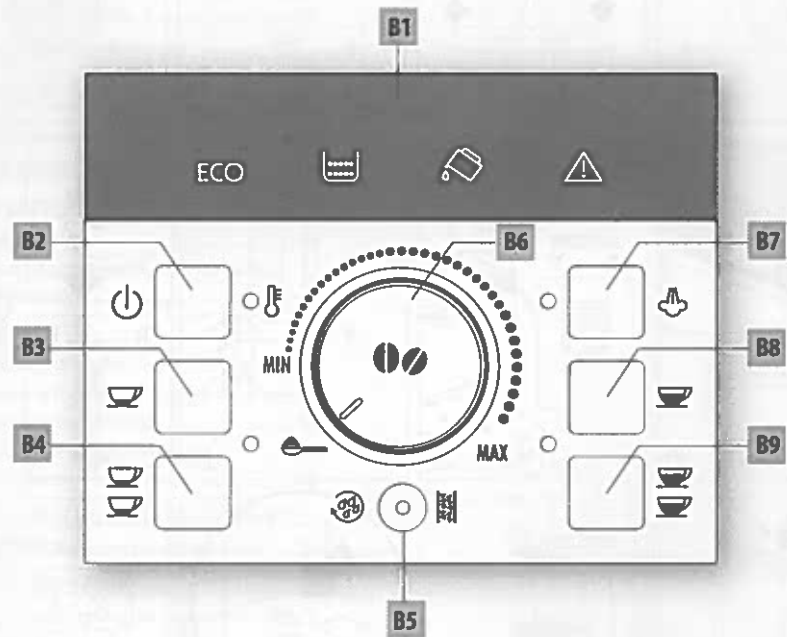

C

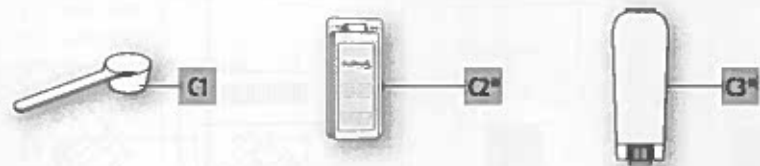

A

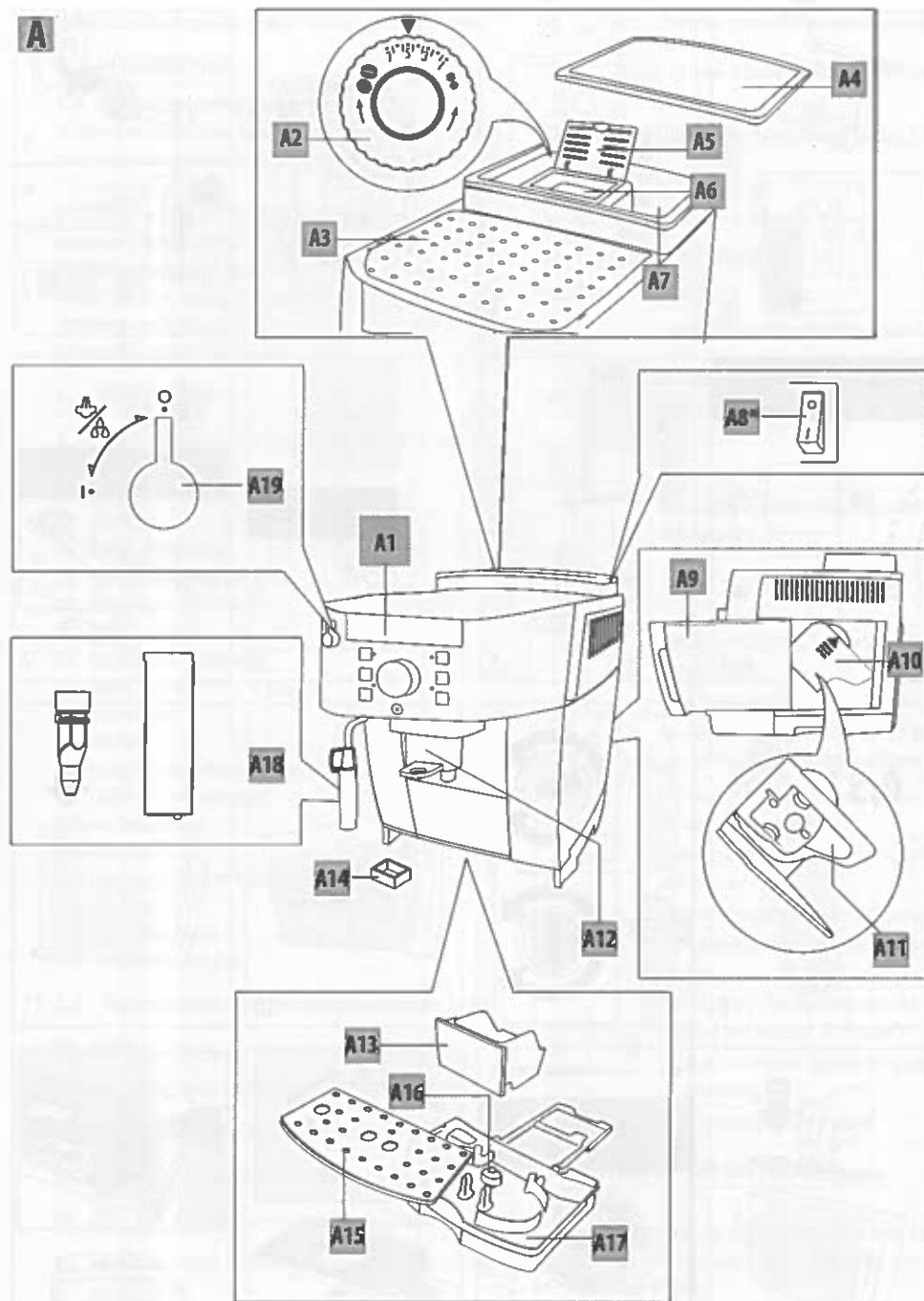

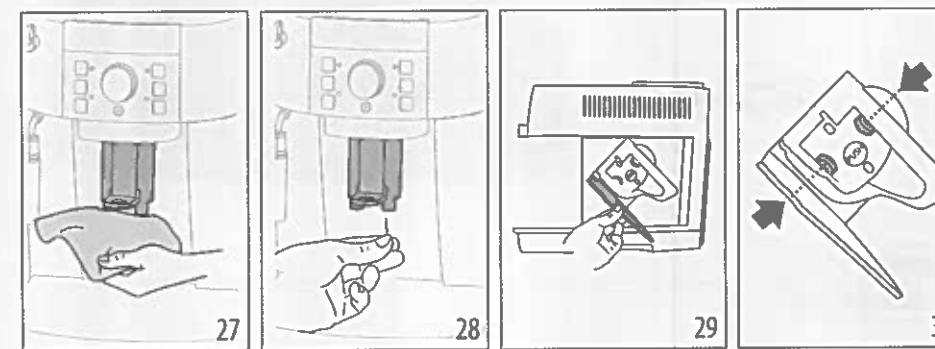
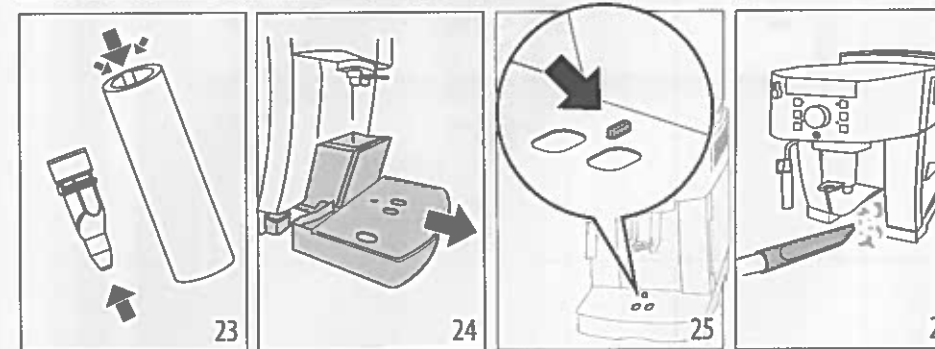
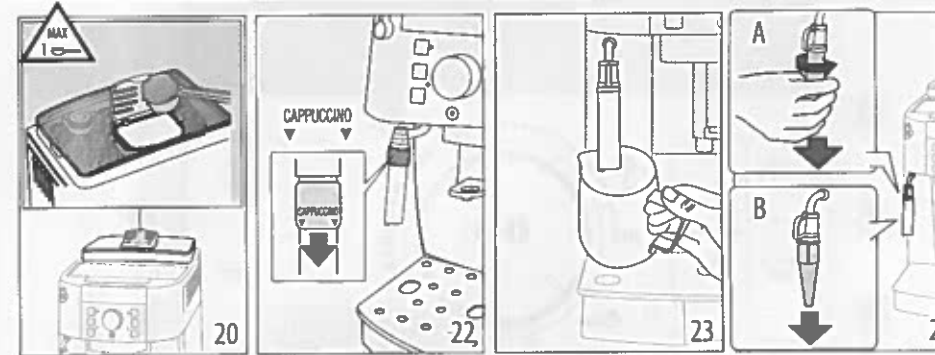
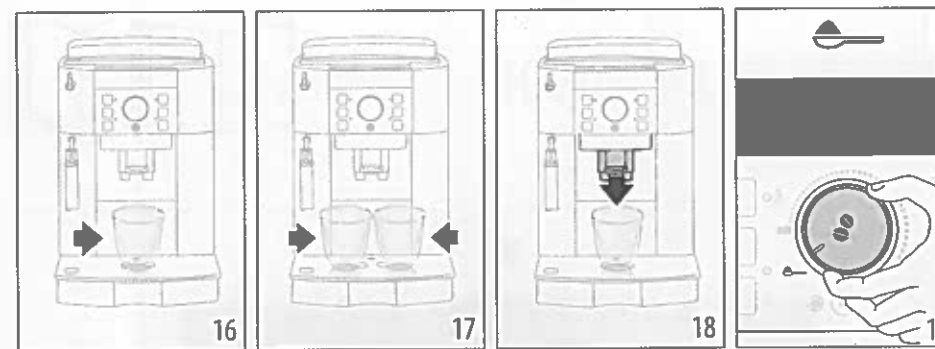
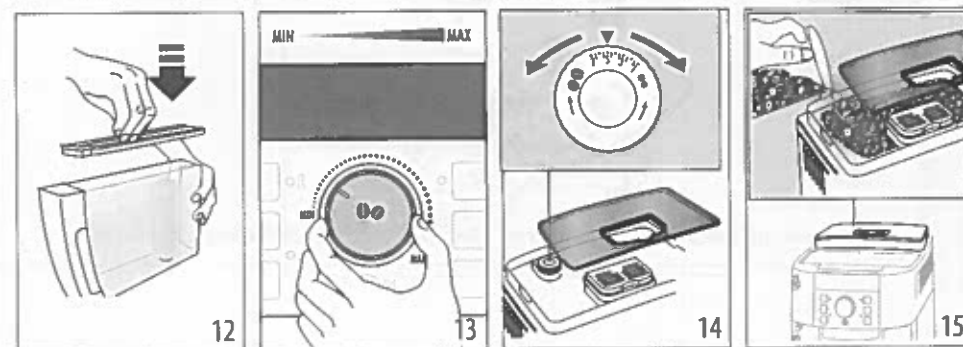
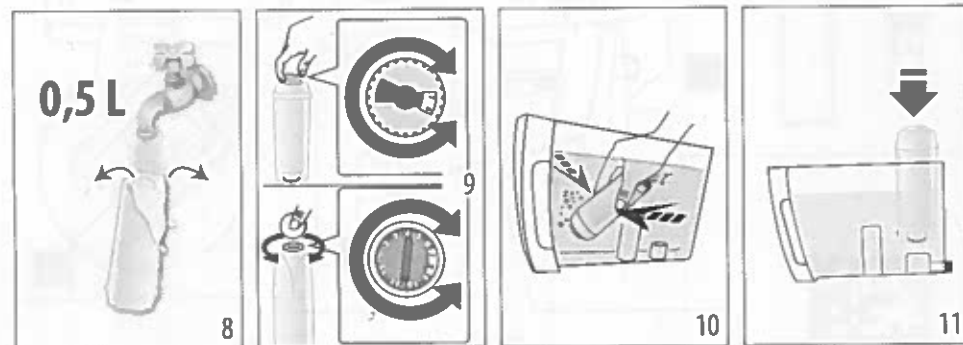
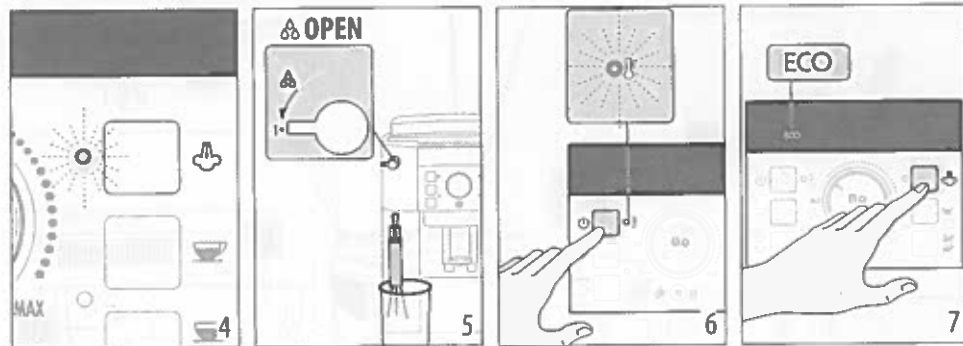
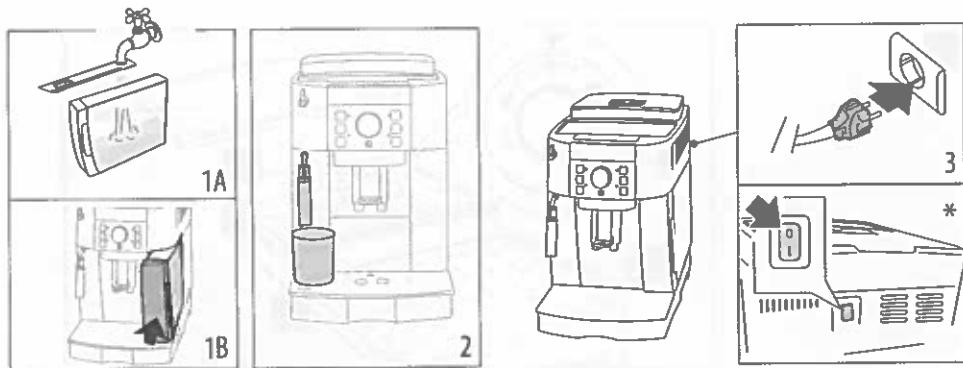

CONTENTS

1. INTRODUCTION	7
1.1 Troubleshooting and repairs.....	7
2. DESCRIPTION	7
2.1 Description of the appliance (page 3 - A)	7
2.2 Description of the control panel (page 2 - B).....	7
2.3 Description of the accessories (page 2 - C).....	7
2.4 Description of lights	7
4. TURNING THE MACHINE ON	8
5. TURNING THE APPLIANCE OFF	8
6. AUTO-OFF	8
7. ENERGY SAVING	9
8. WATER SOFTENER FILTER (*IF PRESENT)	9
8.1 Installing the filter	9
8.2 Removal and replacement of the water softener filter	9
9. MAKING COFFEE	9
9.1 Selecting the coffee taste.....	9
9.2 Selecting the quantity of coffee in the cup.....	9
9.3 Adjusting the coffee mill	10
9.4 Setting the temperature	10
9.5 Tips for a hotter coffee.....	10
10. MAKING COFFEE USING COFFEE BEANS	10
10.1 Making coffee using pre-ground coffee	10
11. MAKING CAPPUCCINO	11
11.1 Cleaning the cappuccino maker after use.....	11
12. HEATING WATER	11
13. CLEANING	11
13.1 Cleaning the machine	11
13.2 Cleaning the internal circuit	12
13.3 Cleaning the coffee grounds container.....	12
13.4 Cleaning the drip tray and condensate tray.....	12
13.5 Cleaning the inside of the coffee machine.....	12
13.6 Cleaning the water tank.....	12
13.7 Cleaning the coffee spouts	12
13.8 Cleaning the pre-ground coffee funnel	12
13.9 Cleaning the infuser	12
14. DESCALE	13
15. TECHNICAL DATA	14
15.1 Tips for Energy Saving	14
16. EXPLANATION OF LIGHTS	15
17. TROUBLESHOOTING	16

Before using the appliance, always read the safety warnings.

1. INTRODUCTION

1.1 Troubleshooting and repairs

In the event of problems, first try and resolve them by reading the information given in sections "16. Explanation of lights" and "17. Troubleshooting".

If this does not resolve the problem or you require further information, you should consult Customer Services by calling the number given on the annexed "Customer Service" sheet.





If your country is not among those listed on the sheet, call the number given in the guarantee. If repairs are required, contact De'Longhi Customer Services only.



2. DESCRIPTION

2.1 Description of the appliance (page 3 - A)

- A1. Control panel
- A2. Grinding adjustment dial
- A3. Cup shelf
- A4. Beans container lid
- A5. Pre-ground coffee funnel lid
- A6. Pre-ground coffee funnel
- A7. Beans container
- A8. Main switch (*if present)
- A9. Water tank with lid* (*if present)
- A10. Infuser door
- A11. Infuser
- A12. Coffee spouts (adjustable height)
- A13. Coffee grounds container
- A14. Condensate tray
- A15. Cup tray
- A16. Drip tray water level indicator
- A17. Drip tray
- A18. Cappuccino maker
- A19. Steam/hot water dial

2.2 Description of the control panel (page 2 - B)











- B1. Lights
- B2.  button: turns the appliance on and off
- B3.  button: to make 1 cup of short espresso coffee.
- B4.  button: to make 2 cups of short espresso coffee.
- B5.  button: to rinse or descale the appliance
- B6. selection dial: turn to select coffee quantity or to use pre-ground coffee
- B7.  button: to deliver steam to make hot milk-based coffees

- B8.  button: to make 1 cup of long espresso coffee
- B9.  button: to make 2 cups of long espresso coffee.

2.3 Description of the accessories (page 2 - C)

- C1. Measure
- C2. Descaler bottle (*if present)
- C3. Water softener filter (*if present)

2.4 Description of lights

LIGHT	MEANING
	Light flashing: the machine is heating up.
 	The appliance is delivering one or two cups of short coffee.
 	The appliance is delivering one or two cups of long coffee.
	Light on steadily: the "steam" function has been selected. Light flashing: you must turn the steam dial.
	An alarm is displayed on the control panel (see section "16. Explanation of lights").
	Light on steadily: the grounds container is missing and must be inserted. Light flashing: the grounds container is full and must be emptied.
	Light on steadily: the water tank is missing. Light flashing: there is not enough water in the tank.
	Light flashing: the appliance must be descaled (see section "14. Descale").
	Light on steadily: the appliance is performing a descaling cycle.
ECO	"Energy Saving" mode is active.

3. SETTING UP THE APPLIANCE

Please note:

- The first time you use the appliance, rinse with hot water all removable accessories which may come into contact with water or milk.
- The first time you use the machine, the water circuit is empty and the appliance could be very noisy. The noise becomes less as the circuit fills.

- Possible traces of coffee in the mill are the result of operating tests performed on the appliance before sale, proof of the meticulous care and attention we invest in our products.

Proceed as described:

1. Remove the water tank «A9», fill to the MAX line with fresh water «fig. 1A» then put back in the appliance «fig. 1B».
2. Place a container with a minimum capacity of 100 ml under the cappuccino maker «A18» «fig. 2».
3. Connect the appliance to the mains supply.
4. In models with main switch «A8», make sure it is pressed in the I position «fig. 3».
5. The  light «B7» flashes on the control panel «fig. 4».
6. Turn the steam dial «A19» to the I position «fig. 5». Water is delivered from the cappuccino maker, then the appliance goes off.
7. Turn the steam dial to the 0 position.
8. The coffee machine is now ready for normal use.

Please note:

- The first time you use the coffee machine, you need to make 4-5 cups of coffee or 4-5 cappuccinos before it starts to give satisfactory results.
- To enjoy your coffee even more and improve the performance of your appliance, we recommend installing a water softener filter «C3» as described in section "8. Water softener filter (*if present)". If your model is not provided with a filter, you can purchase one from De'Longhi Customer Services.



4. TURNING THE MACHINE ON

Please note:

- Each time the appliance is turned on, it performs an automatic preheat and rinse cycle which cannot be interrupted. The appliance is ready for use only once this cycle is complete.
- *Models with main switch «A8» only:* Before turning the appliance on, make sure the main switch on the back of the appliance is in the I position «fig. 3».

Danger of scalding!

During rinsing, a little hot water comes out of the coffee spouts «A12» and is collected in the drip tray underneath. Avoid contact with splashes of water.

- To turn the appliance on, press the  button «B2» «fig. 6». The  light flashes while the appliance is heating up and performing an automatic rinse cycle. By circulating hot water, the appliance heats both the boiler and the internal circuits.

The appliance is at temperature when the light goes off and the coffee lights come on.

5. TURNING THE APPLIANCE OFF

Whenever the coffee machine is turned off after being used to make coffee, it performs an automatic rinse cycle.

Danger of scalding!

During rinsing, a little hot water flows from the coffee spouts «A12». Avoid contact with splashes of water.

To turn the appliance off, press the  button «B2». The appliance performs a rinse cycle then goes off.

Please note:

If you will not be using the appliance for some time, we recommend unplugging it from the mains socket. In models with main switch «A8», just press it to the 0 position.



Important!











Always turn the appliance off with the  button (standby) before unplugging from the mains socket or (if present) pressing the main switch to the 0 position.

6. AUTO-OFF

The period of time can be changed so that the appliance switches off after being idle for 15 or 30 minutes, or after 1, 2 or 3 hours.

To change the Auto-off setting, proceed as follows:

1. Confirm with the  button «B2». (The appliance must be plugged into the mains socket and the main switch «A8» (if present) must be in the I position «fig. 3»).
2. Press and hold the  button «B9» until the lights on the control panel «B» come on.
3. Press the  button «B3» (on the left of the dial «B6») until the lights corresponding to the delay before the appliance goes off automatically come on:





AUTO-OFF TIME	CORRESPONDING LIGHTS
15 minutes	ECO 
30 minutes	ECO 
1 hour	ECO  
2 hours	ECO   
3 hours	ECO    

4. Press the  button «B8» (on the right of the dial) to confirm the selection. The lights go off.

7. ENERGY SAVING

Energy saving mode is active when the green ECO light is on.

To disable or enable "Energy Saving", proceed as follows:

1. Confirm with the  button «B2». (The appliance must be plugged into the mains socket and the main switch «A8» (if present) must be in the I position «fig. 3»).
2. Press and hold the  button «B7» until the ECO light on the control panel comes on «fig. 7».
3. To disable the mode, press the  button «B3» (on the left of the dial «B6»). The ECO light flashes.
4. To re-enable the mode, press the  button (on the left of the dial «B6») again. The ECO light comes on steadily.
5. Press the  button «B8» (on the right of the dial «B6») to confirm the selection. The ECO light goes off.

Please note:

When in energy saving mode, a few seconds may elapse before the first coffee is delivered as the appliance must heat up again.

8. WATER SOFTENER FILTER (*IF PRESENT)

Certain models are fitted with a water softener filter «C3». If this is not the case with your model, you are recommended to purchase one from De'Longhi Customer Services.

Important:

- Keep in a cool dry place out of direct sunlight.
- After opening the packaging, use the filter at once.
- Remove the filter before descaling the machine.

To use the filter correctly, follow the instructions below.

8.1 Installing the filter

1. Take the filter «C3» out of its packet and rinse under about 0.5 litre of running water «fig. 8».
2. Turn the date indicator disk until the next two months of use are displayed «fig 9».

Please note:

The filter lasts about two months if the appliance is used normally. If the coffee machine is left unused with the filter installed, it will last a maximum of three weeks.

3. Extract the tank «A9» from the appliance and fill with water «fig. 1A».
4. Insert the filter in the water tank and immerse it completely, sloping it to enable the air bubbles to escape «fig. 10».
5. Insert the filter in the filter housing and press fully home «fig. 11».
6. If present, close the tank with the lid «fig. 12», then replace the tank in the machine.
7. Place a container with a minimum capacity of 500 ml under the cappuccino maker «A18».
8. Turn the steam dial «A19» to the I position to deliver hot water.

9. Deliver at least 500 ml of hot water, then turn the steam dial back to the 0 position.

Please note:

Occasionally one delivery of hot water is not enough to install the filter and the  lights will come on during installation.

If this happens, repeat the installation procedure from point «8». The filter is now active and you can use the coffee machine.

8.2 Removal and replacement of the water softener filter

After two months (see date indicator disk), or if the appliance has not been used for 3 weeks, the filter «C3» must be removed from the tank «A9» and replaced with a new one. Then the installation procedure above must be repeated.

9. MAKING COFFEE

9.1 Selecting the coffee taste

Turn the coffee taste selection dial «B6» to set the required taste «fig. 13». Turning towards "MAX" increases the quantity of coffee beans that will be ground by the machine and consequently the coffee will be stronger.





Turn the dial to MIN for an extra mild coffee and to MAX for an extra strong coffee.

Please note:

- The first time you use the appliance, you will need to identify the correct dial position for your preferred strength of coffee.
- Do not turn the dial too far towards MAX, otherwise the coffee may be delivered too slowly (a drop at a time), particularly when making two cups of coffee at the same time.

9.2 Selecting the quantity of coffee in the cup

The appliance is set by default to automatically make the following quantities of coffee:

COFFEE	QUANTITY (ML)
 short coffee «B3»	≈ 40
 long coffee «B8»	≈ 120
 2 x short coffees «B4»	2 x ≈ 40
 2 long coffees «B9»	2 x ≈ 120

To change the quantity of coffee the appliance delivers automatically into the cup, proceed as described below:

- press the button corresponding to the quantity to be modified and hold it down until the light flashes and the appliance starts delivering coffee, then release;

- when the coffee in the cup reaches the required level, press the same button again to memorise the new amount.

The machine is now reprogrammed with the new quantities.

9.3 Adjusting the coffee mill

The coffee mill is set by default to prepare coffee correctly and should not require regulating initially.

However, if after making the first few coffees you find that the coffee is either too weak and not creamy enough or delivery is too slow (a drop at a time), this can be corrected by adjusting the grinding adjustment dial «A2» «fig. 13».

Please note:

The grinding adjustment dial must only be turned when the coffee mill is in operation during the initial phase of coffee preparation.



If the coffee is delivered too slowly or not at all, turn one click clockwise. For fuller bodied creamier coffee, turn one click anticlockwise (do not turn more than one click at a time otherwise the coffee could be delivered a

drop at a time).

These adjustments will only be evident after at least 2 cups of coffee have been delivered. If this adjustment does not produce the desired result, turn the dial another click.

9.4 Setting the temperature

To change the temperature of the water used to make the coffee, proceed as follows:

- Confirm with the button «B2». (The appliance must be plugged into the mains socket and the main switch «A8» (if present) must be in the I position «fig. 3»).
- Press the button «B3» (on the left of the dial «B6») and hold down until the lights on the control panel come on;
- Press the button to select the required temperature:

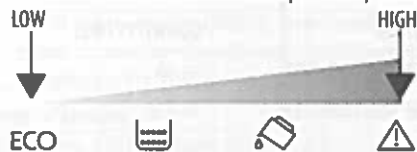

- Press the button «B8» (on the right of the dial «B6») to confirm the selection. The lights go off.

Please note:

Varying the temperature has most effect for long beverages.

9.5 Tips for a hotter coffee

For hotter coffee, you should:

- before delivering the coffee perform a rinse cycle by pressing the button «B5»). Hot water is delivered from

the spouts «A12», heating the internal circuits of the appliance and thus raising the coffee temperature.

- warm the cups by rinsing them with hot water (using the hot water function).
- set a hotter coffee temperature (see section "9.4 Setting the temperature").

10. MAKING COFFEE USING COFFEE BEANS

Important!

Do not use caramelised or candied coffee beans as they could stick to the coffee mill and damage it.

- Fill the container «A7» with coffee beans «fig. 15».
- Place under the coffee spouts «A12»:
 - 1 cup, to make 1 coffee «fig. 16»;
 - 2 cups, to make 2 coffees «fig. 17».
- Lower the spouts as near as possible to the cup. This makes a creamier coffee «fig. 18».
- Press the button corresponding to the required coffee:

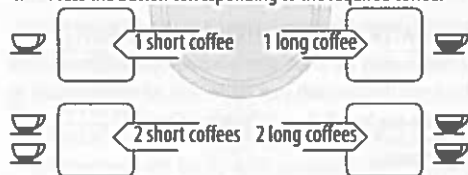

- Preparation begins and the light corresponding to the selected button flashes on the control panel.

Once the coffee has been made, the appliance is ready to make the next beverage.

Please note:

- While the machine is making coffee, delivery can be interrupted at any moment by pressing one of the coffee buttons.
- At the end of delivery, to increase the quantity of coffee in the cup, just press one of the coffee icons (within 3 seconds).
- For hotter coffee, see section "9.5 Tips for a hotter coffee".

Important!

- If the coffee is delivered a drop at a time, too weak and not creamy enough or too cold, read the tips in section "17. Troubleshooting".
- Lights may light up on the control panel during use. Their meaning is given in section "16. Explanation of lights".

10.1 Making coffee using pre-ground coffee

Important!

- Never place coffee beans in the pre-ground coffee funnel «A6» as this could damage the appliance.
- Never add pre-ground coffee when the machine is off or it



could spread through the inside of the machine and dirty it. This could damage the machine.

- Never use more than 1 level measure «C1» as it could soil the inside of the coffee machine or block the funnel.

Please note:

When you use pre-ground coffee, you can only make one cup of coffee at a time.

- Make sure the appliance is on.
- Turn the coffee taste selection dial «B6» anticlockwise as far as it will go to the position «fig. 19».
- Make sure the funnel «A6» is not blocked, then add one level measure «C1» of pre-ground coffee «fig. 20».
- Place a cup under the coffee spouts «A12».
- Press the corresponding one cup coffee button («B3» or «B8»)
- Preparation begins.

11. MAKING CAPPUCCINO

Danger of scalding!

During preparation, steam is given off. Take care to avoid scalds.

- When preparing cappuccino, make the coffee in a large cup;
- Fill a container (preferably one with a handle to avoid scalding) with about 100 ml of milk for each cappuccino. When choosing the appropriate size of container, remember that the milk doubles or triples in volume;

Please note:

- For a richer and denser froth, use skimmed or partially skimmed milk from the refrigerator (about 5°C). To avoid producing milk with poor froth or large bubbles, always clean the cappuccino maker «A18» as described in the following section "11.1 Cleaning the cappuccino maker after use".
 - The quality of the froth will vary depending on:
 - type of milk or vegetable beverage;
 - brand used;
 - ingredients and nutritional value
- Press the button «B7». The light flashes.
 - Immerse the cappuccino maker in the milk container «fig. 21».
 - After a few seconds, when the light flashes, turn the steam dial «A19» to the I position «fig. 5». Steam is delivered from the cappuccino maker, giving the milk a creamy frothy appearance and making it more voluminous.
 - For a creamier froth, rotate the container with slow movements in an upward direction. (Steam should not be generated by the machine for more than 3 minutes continuously).
 - When you have obtained the required froth, stop steam delivery by turning the steam dial back to the 0 position.

Danger of scalding!

Stop steam delivery before removing the container with the frothed milk to avoid burns caused by splashes of boiling milk.

- Add the milk froth to the coffee prepared previously. The cappuccino is ready. Sweeten to taste and, if desired, sprinkle the froth with a little cocoa powder.

11.1 Cleaning the cappuccino maker after use

Always clean the cappuccino maker «A18» after use to avoid the build-up of milk residues and prevent the spouts from clogging.

- Place a container under the cappuccino maker and run a little water for a few seconds by turning the steam dial «A19» to the I position «fig. 5». Then turn the steam dial to the 0 position to stop the flow of hot water.
- Wait a few minutes for the cappuccino maker to cool down. Grip the handle of the cappuccino maker tube firmly in one hand and with the other rotate the cappuccino maker anticlockwise «fig. 21», then remove by pulling downwards.
- Remove the steam connection nozzle as well, by pulling downwards «fig. 22».
- Make sure the two holes shown by the arrow in fig. 23 are not blocked. If necessary, clean using a toothpick.
- Wash all parts of the cappuccino maker thoroughly with a sponge and warm water.
- Reinsert the nozzle and replace the cappuccino maker on the nozzle, pushing it upwards and turning it until it is attached.

12. HEATING WATER

Danger of scalding!

Never leave the machine unattended while delivering hot water. The spout of the cappuccino maker «A18» becomes hot while water is being delivered and must be held by the handle only.

- Place a container under the cappuccino maker «A18» (as close as possible to avoid splashes).
- Turn the steam dial «A19» to the I position. Delivery begins.
- Stop by turning the steam dial to the 0 position.

Please note:

If "energy saving" mode is active, you may have to wait a few seconds before the hot water is delivered.

13. CLEANING

13.1 Cleaning the machine

The following parts of the machine must be cleaned regularly:

- the appliance's internal circuit;
- coffee grounds container «A13»;
- drip tray «A17» and condensate tray «A14»;
- water tank «A9»;
- coffee spouts «A12»;
- cappuccino maker «A18»;

- pre-ground coffee funnel «A6»;
- infuser «A11», accessible after opening the infuser door «A10»;
- control panel «A1».

Important!

- Do not use solvents, abrasive detergents or alcohol to clean the coffee machine. With De'Longhi superautomatic coffee machines, no chemical products are required for cleaning purposes.
- None of the components can be washed in a dishwasher.
- Do not use metal objects to remove encrustations or coffee deposits as they could scratch metal or plastic surfaces.

13.2 Cleaning the internal circuit

If the appliance is not used for more than 3/4 days, before using it again, we strongly recommend switching it on and:

- performing 2/3 rinse cycles by pressing the button «B5»;
- delivering hot water by turning the hot water/steam dial «A19» to the 1 position.

Please note:

- After cleaning, it is normal for the grounds container «A13» to contain water.

13.3 Cleaning the coffee grounds container

When the light flashes, the coffee grounds container «A13» must be emptied and cleaned. Unless you clean the grounds container, the light will continue to flash and the appliance cannot be used to make coffee.

To clean (with the machine on):

- Remove the drip tray «A17» «fig. 24», empty and clean.
- Empty the grounds container «A13» and clean thoroughly to remove all residues left on the bottom.
- Check the red condensate tray «A14» and empty if necessary.

Important!

When removing the drip tray, the grounds container must be emptied, even if it contains few grounds.

If this is not done, when you make the next coffees, the grounds container may fill up more than expected and clog the machine.

13.4 Cleaning the drip tray and condensate tray

Important!

If the drip tray «A17» is not emptied regularly, the water could overflow from the edge and seep inside or around the machine. This could damage the machine, the surface it rests on or the surrounding area.

The drip tray is fitted with a level indicator «A16» (red) showing the amount of water it contains «fig. 25». Before the indicator protrudes from the cup tray, the drip tray must be emptied and cleaned.

To remove the drip tray:

1. Remove the drip tray «A17» and grounds container «A13» «fig. 24»;
2. Empty the drip tray and grounds container and wash them;
3. Check the condensate tray «A14» and empty if necessary.
4. Replace the drip tray and grounds container.

13.5 Cleaning the inside of the coffee machine

Danger of electric shock!

Before cleaning internal parts, the machine must be turned off (see section "5. Turning the appliance off") and unplugged from the mains power supply. Never immerse the machine in water.

1. Check regularly (about once a week) that the inside of the appliance (accessible after removing the drip tray) is not dirty. If necessary, remove coffee deposits with a sponge.
2. Remove all residues with a vacuum cleaner «fig. 26».

13.6 Cleaning the water tank

1. Clean the water tank «A9» regularly (about once a month) and whenever you replace the water softener filter «C3» (if present) with a damp cloth and a little mild washing up liquid.
2. Remove the filter (if present) and rinse with running water.
3. Replace the filter (if provided), fill the tank with fresh water and replace the tank.
4. (Models with water softener filter only) Deliver about 100 ml of water.

13.7 Cleaning the coffee spouts

1. Clean the coffee spouts «A12» with a sponge or cloth «fig. 27».
2. Check the holes in the coffee spouts are not blocked. If necessary, remove coffee deposits with a toothpick «fig. 28».

13.8 Cleaning the pre-ground coffee funnel

Check regularly (about once a month) that the pre-ground coffee funnel «A6» is not blocked. If necessary, remove coffee deposits.

13.9 Cleaning the infuser

The infuser «A11» must be cleaned at least once a month.

Important!

The infuser cannot be extracted when the machine is on.

1. Make certain that the machine has run the shutdown procedure correctly (see "5. Turning the appliance off").
2. Remove the water tank «A9».
3. Open the infuser door «A10» «fig. 29» on the right side of the appliance.
4. Press the two coloured release buttons inwards and at the same time pull the infuser outwards «fig. 30».

Important!

Clean the infuser without using washing up liquid as it could be damaged.

5. Soak the infuser in water for about 5 minutes, then rinse under the tap.
6. Clean coffee residues from the support where the infuser rests.
7. After cleaning, replace the infuser by sliding it onto the internal support «fig. 31», then push the PUSH symbol fully in until it clicks into place.

Please note:

If the infuser is difficult to insert, before insertion, adapt it to the right size by pressing the two levers shown in fig. 32.

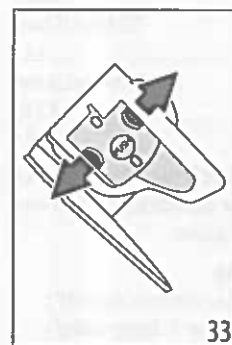
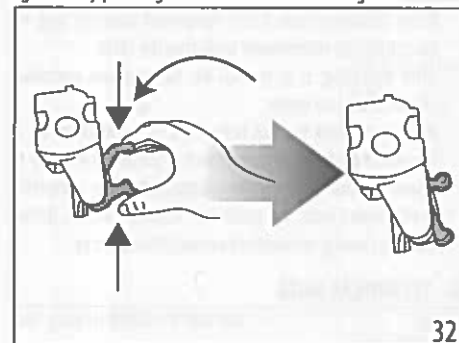

8. Once inserted, make sure the two coloured buttons have snapped out «fig. 33».
9. Close the infuser door.
10. Put the water tank back.

14. DESCALE

Important!

- Before use, read the instructions and the labelling on the descaler pack.
- It is important to use De'Longhi descaler only. Using unsuitable descaler and/or performing descaling incorrectly may result in faults not covered by the manufacturer's guarantee.
- Descaler could damage delicate surfaces. If the product is accidentally spilt, dry immediately.

To descale	
Descaler	De'Longhi descaler
Container	Recommended capacity: 2l
Time	~45min

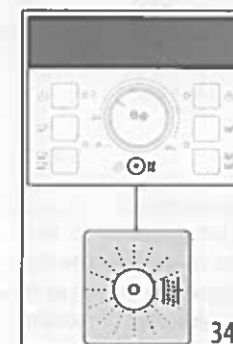

Descal the appliance when the light «B5» «fig. 34» on the control panel «B» flashes.

1. Turn the machine on and wait until it is ready for use.
2. Empty the drip tray «A17» and grounds container «A13» and return both to their positions in the machine.
3. Empty the water tank «A9» completely and remove the water softener filter «C3» if present).

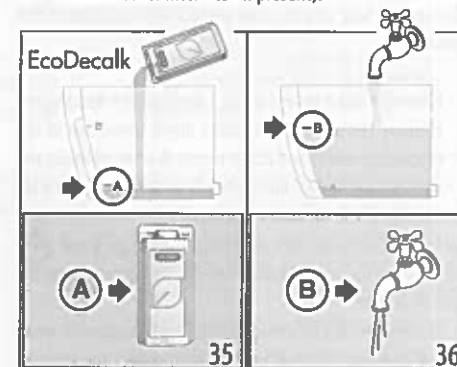

4. Pour the descaler «C2» into the tank up to level A (corresponding to a 100ml pack) marked on the inner surface of the tank «fig. 35», then add a litre of water up to level B «fig. 36» and put the water tank back in the appliance.
5. Place a container with a minimum capacity of 2 litres under the cappuccino maker «A18» and coffee spouts «A12» «fig. 37».

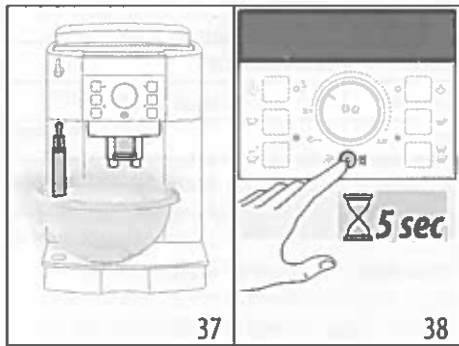

6. Wait for the coffee lights to come on steadily.
7. Press and hold the button «B5» «fig. 38» for at least 5 seconds to confirm that you have added the solution and begin the descaling procedure. The light on the button comes on steadily to indicate that the descaling programme has begun.
8. The light flashes to indicate the hot water/steam dial «A19» must be turned to the I position.

Important! Danger of scalding

Hot water containing acid flows from the cappuccino maker and coffee spouts. Take care to avoid contact with splashes of this solution.

9. When the dial is turned to the I position, the descale programme starts and the descaler liquid comes out of the cappuccino maker and coffee spouts. A series of rinses and pauses is performed automatically to remove all the scale residues inside the coffee machine.

After about 25 minutes, descaling stops and the and lights flash on the control panel. Turn the hot water/steam dial to the 0 position.

10. The appliance is now ready for rinsing through with clean water. Empty the container used to collect the descaler solution. Extract the water tank, empty, rinse under running water, fill with fresh water up to the MAX level and put back in the appliance. The light flashes.
11. Place the container used to collect the descaler solution empty under the cappuccino maker and coffee spouts «fig. 37».
12. Turn the hot water/steam dial to the I position to begin rinsing. Hot water is delivered first from the cappuccino maker, to continue and end with the coffee spouts.
13. When the water tank is completely empty, the and lights flash on the control panel. Turn the steam/hot water dial to the 0 position.
14. Empty the container used to collect the rinsing water. Remove the water tank, replace the water softener filter

(if removed previously), fill the tank up to the MAX level with cold water and insert in the appliance. The steam light flashes.

15. Place the container used to collect the rinsing water empty under the cappuccino maker;
16. Turn the hot water/steam dial to the I position. The appliance begins rinsing again from the cappuccino maker only.
17. When it has finished, the steam light flashes on the control panel. Turn the hot water/steam dial to the 0 position.
18. Top up the water tank with fresh water to the MAX level and put back in the machine.

The descaling cycle is now complete.

Please note!

- If the descaling cycle is not completed correctly (e.g. no electricity) we recommend repeating the cycle.
- After descaling, it is normal for the grounds container «A13» to contain water.
- If the water tank has not been filled to the MAX level, at the end of descaling, the appliance requests a third rinse to guarantee that the descaler solution has been completely eliminated from the machine's internal circuits. Before starting rinsing, remember to empty the drip tray.

15. TECHNICAL DATA

Voltage:	220-240 V~ 50/60 Hz max. 10A
Absorbed power:	1450 W
Pressure:	1.5 MPa (15 bars)
Max. water tank capacity:	1.8 L
Size LxDxH:	240x430x350 mm
Weight:	8.9 Kg
Max. beans container capacity:	250 g







De'Longhi reserves the right to modify the technical specification and styling of its products at any moment, without compromising their functionality and quality.

15.1 Tips for Energy Saving

- Set auto-off to 15 minutes (see section "6. Auto-off");
- Enable Energy Saving (see section "7. Energy saving");
- When requested by the machine, perform the descaling cycle.

16. EXPLANATION OF LIGHTS



LIGHT DISPLAYED	POSSIBLE CAUSE	REMEDY
	The steam/hot water dial must be turned «A19»	Turn the hot water/steam dial.
FLASHING	Insufficient water in the tank «A9».	Fill the tank with water and/or insert it correctly, pushing it as far as it will go until it clicks into place.
FLASHING	The tank «A9» is not correctly in place.	Insert the tank correctly and press as far as it will go.
FLASHING	The grounds container «A13» is full.	Empty the grounds container and drip tray «A17», clean and replace. Important: when removing the drip tray, the grounds container MUST be emptied, even if it contains few grounds. If this is not done, when you make the next coffees, the grounds container may fill up more than expected and clog the machine.
FLASHING	After cleaning, the grounds container «A13» has not been replaced.	Remove the drip tray «A17» and insert the grounds container.
FLASHING	The grinding is too fine and the coffee is delivered too slowly or not at all.	Repeat coffee delivery and turn the grinding adjustment dial «A2» «fig. 10» one click clockwise towards 7 while the coffee mill is in operation. If after making at least 2 coffees delivery is still too slow, repeat the correction procedure, turning the grinding adjustment dial another click (see section "9.3 Adjusting the coffee mill"). If the problem persists, turn the steam dial «A19» to the I position and deliver some water from the cappuccino maker.
FLASHING	If the water softener filter «C3» is present, an air bubble may have been released inside the circuit, obstructing delivery.	Deliver a little water from the cappuccino maker «A18» by turning the steam/hot water dial «A19» to the I position until the flow is regular «fig. 5».

LIGHT DISPLAYED	POSSIBLE CAUSE	REMEDY
 FLASHING	The pre-ground coffee function has been selected without placing any pre-ground coffee in the funnel «A6».	Place pre-ground coffee in the funnel or deselect the "pre-ground" function.
 FLASHING	The machine must be descaled.	The descaling procedure described in section "14. Descal" needs to be performed.
 FLASHING	Too much coffee has been used.	Select a milder taste or reduce the quantity of pre-ground coffee, then make the coffee again.
 FLASHING	The coffee beans have run out.	Fill beans container «A7».
	The pre-ground coffee funnel «A6» is clogged.	Empty the funnel as described in section "13.8 Cleaning the pre-ground coffee funnel".
 FLASHING	The infuser «A11» has not been replaced after cleaning.	Insert the infuser as described in section "13.9 Cleaning the infuser".
 FLASHING	The inside of the appliance is very dirty.	Clean the inside of the appliance thoroughly, as described in section "13. Cleaning". If the message is still displayed after cleaning, contact a customer service centre.

17. TROUBLESHOOTING

Below is a list of some of the possible malfunctions.

If the problem cannot be resolved as described, contact Customer Services.

PROBLEM	POSSIBLE CAUSE	REMEDY
The coffee is not hot.	The cups were not preheated.	Warm the cups by rinsing them with hot water. Please note: the hot water or rinse function can be used.
	The infuser «A11» has cooled down because 2/3 minutes have elapsed since the last coffee was made.	Before making coffee, heat up the infuser by pressing the   rinse button «B5».
	A low coffee temperature is set.	Set a higher coffee temperature in the menu (see section "9.4 Setting the temperature").
→		

PROBLEM	POSSIBLE CAUSE	REMEDY
The coffee is weak or not creamy enough.	The coffee is ground too coarsely.	Turn the grinding adjustment dial «A2» one click anticlockwise while the grinder is in operation «fig. 8». Continue one click at a time until coffee delivery is satisfactory. The effect is only visible after delivering 2 coffees (see section "9.3 Adjusting the coffee mill").
	The coffee is unsuitable.	Use coffee for espresso machines.
The coffee is delivered too slowly or a drop at a time.	The coffee is ground too finely.	Turn the grinding adjustment dial «A2» one click clockwise while the grinder is in operation «fig. 8». Continue one click at a time until coffee delivery is satisfactory. The effect is only visible after delivering 2 coffees (see section "9.3 Adjusting the coffee mill").
Coffee does not come out of one or both of the spouts.	The spouts are blocked.	Clean the spouts «A12» with a toothpick.
The frothed milk has large bubbles	The milk is not cold enough or is not semi-skimmed.	Ideally, use skimmed or semi-skimmed milk from the refrigerator (about 5°C). If the result is not as expected, try a different brand of milk.
The milk is not frothed	Cappuccino maker «A18» dirty.	Clean as described in section "11.1 Cleaning the cappuccino maker after use".
Steam delivery stops	A safety device shuts off the steam after 3 minutes.	Wait a few minutes and then enable the steam function again.
At the end of descaling, the appliance requests a third rinse	During the two rinse cycles, the water tank has not been filled to the MAX level.	Follow the instructions displayed by the appliance, but first empty the drip tray «A14» to avoid the water overflowing.
The appliance does not come on	It is not plugged into the mains socket.	Plug into the mains socket.
	When present, make sure the main switch «A8» is on.	Press the main switch to the I position «fig. 1».